



RONDO-160

Bezrámečkové designové talířové ventily

Technická data



reddot winner 2023

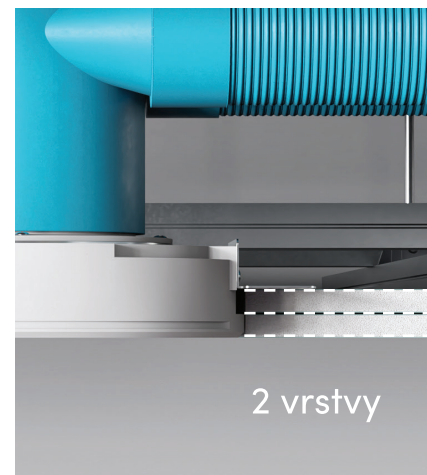
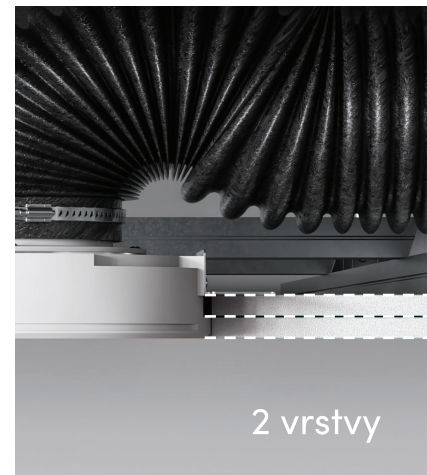
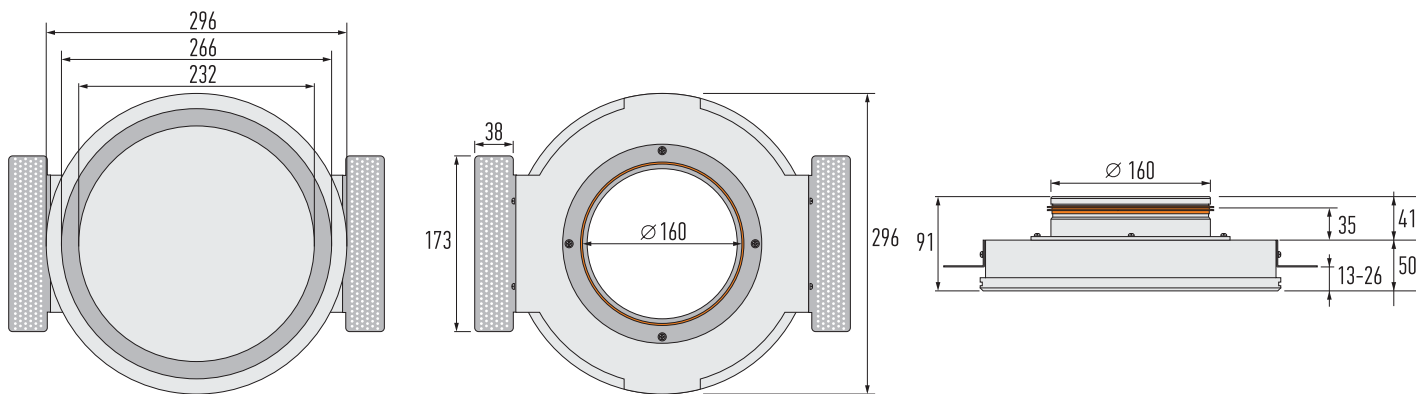

RONDO-160

Technická data

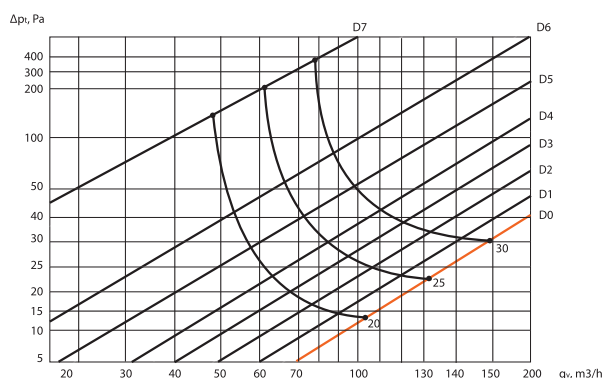
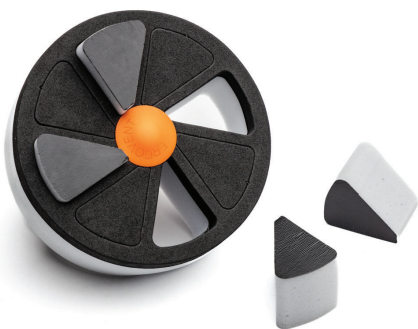
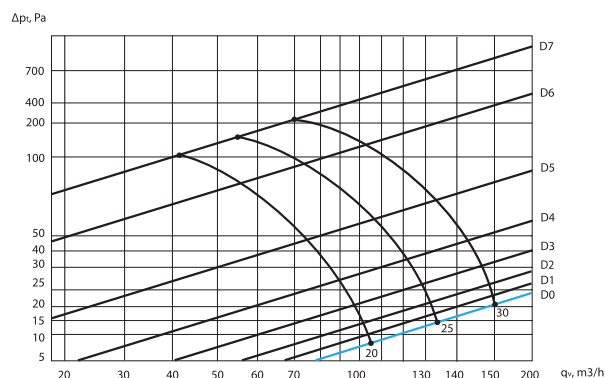
RONDO 160 (přívod)

RONDO 160 (odtah)

K regulaci průtoku je používána polyuretanová klapka.

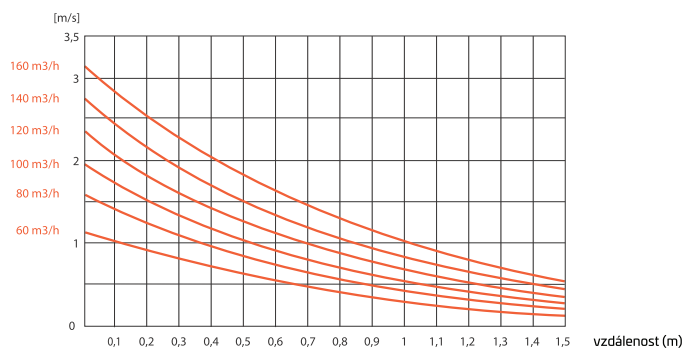
- D0 – bez vložené klapky
- D1 – 1 vložený segment
- D2 – 2 vložené segmenty
- D3 – 3 vložené segmenty
- D4 – 4 vložené segmenty
- D5 – 5 vložených segmentů
- D6 – 6 vložených segmentů
- D7 – 7 vložených segmentů

RONDO 160
rychlost, m/s

Naskenujte QR kód ke stažení montážního návodu.